

Grid Guardian

Armored Wall

Calculations & Analysis

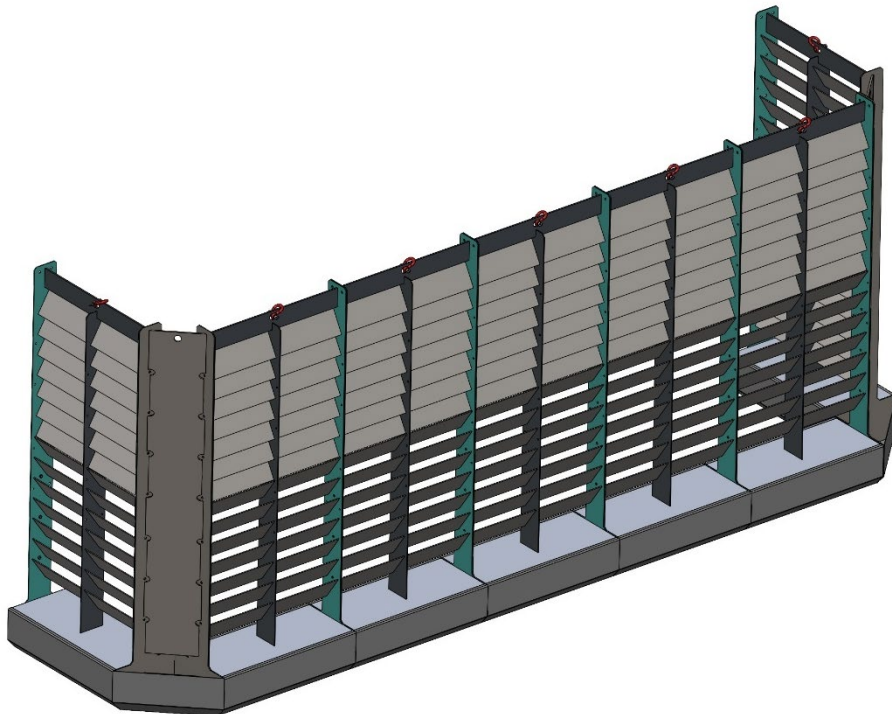

Version 2

Released February 12, 2024

Introduction

This report covers calculations and analysis related to a modular armored wall that can be setup and ballasted on site in section. The report covers several calculations to determine that the wall sections are structurally sound and determine the loads, stresses, and deflections on the armored wall. A combination of CFD (computational fluid dynamics), hand calculations and finite element analysis (FEA) were used in this analysis.

Calculations

There are (4) main scenarios that were examined, including a 200mph wind analysis that as a worst-case scenario. FEA is performed using the results from the hand and excel calculations.

1. Determining the maximum wind speed for a single section, untethered, ballasted with gravel, to tip it over.
2. Determining how much wind a single, tethered unit will hold ballasted with gravel. Will it hold a 200mph wind? What is the force on the tethers at 200 mph, will it hold?
 - Determining whether the 200 mph wind in the previous calculation will cause the base to slide out from under the tethers.
3. Finite Element Analysis (FEA) on one section, tethered, to see effects of 200mph wind force on the wall.
4. Perform FEA of the U-shaped system, 5 panels wide and 3 panels deep at 200 mph. Determine if the unit has the structural integrity to hold a 200mph wind with this setup.

The first two items are represented by the hand, excel calculations, and CFD results shown on the next few pages. The hand calculations use some of the data calculated on the excel sheets, which include the governing equations.

CFD (Computational Fluid Dynamics) on a Single Wall Section: Determine Pressure

A wind load of 200 MPH was applied to the single section in the CFD software to determine wind flow and pressure. This part of the report focuses on the pressure as it is used to calculate the stress on the steel. The results shown in Figure 1 (below) show a distribution of pressure on the steel sections.

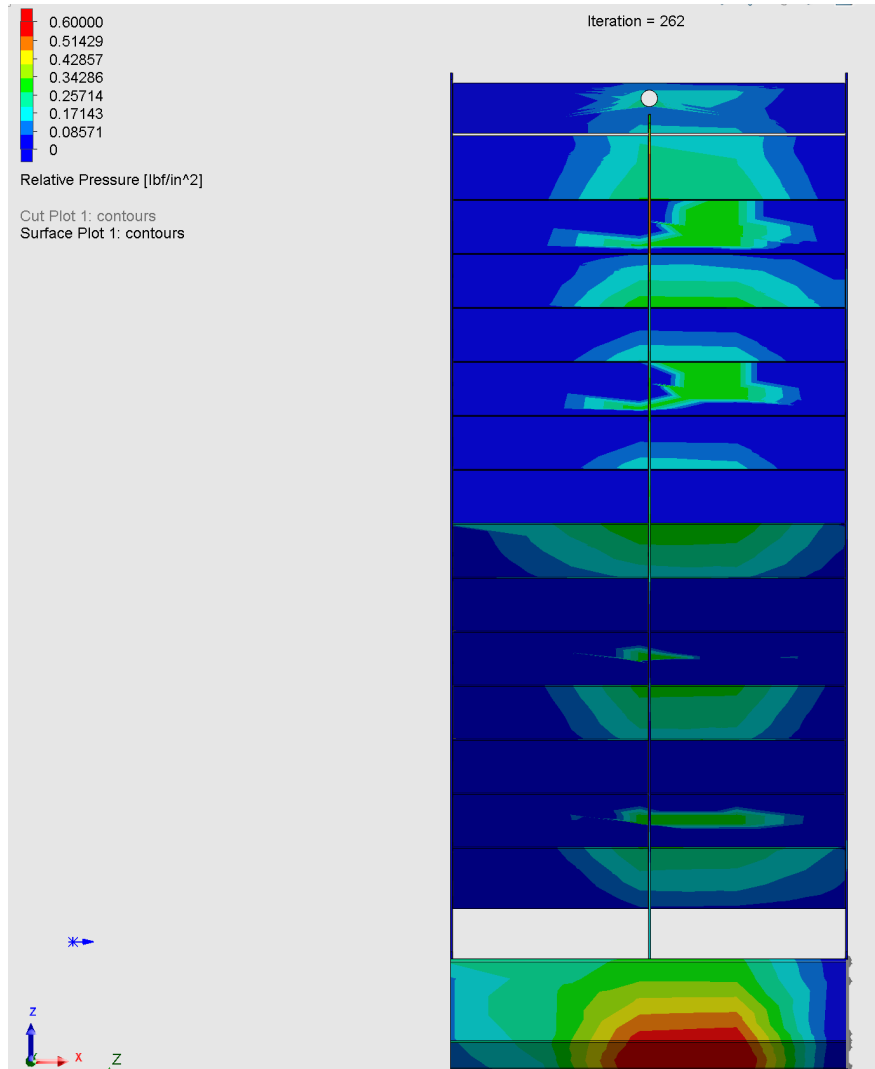

Figure 1: CFD Results: Pressure (psi)

The CFD results show similar levels of pressure as the excel calculations, verifying that the hand calculations were conservative. The CFD results show differences where air is allowed to pass through the louvers, which is not captured by hand calculations. This is a conservative approach. The bottom of the structures shows the highest wind load as there is no area for the wind to escape, which matches what is seen in the hand calculations. The pressure levels are generally around 0 to 0.25 psi where air can pass through. The hand calculations show 0.5psi. Since the results correlate closely, 0.5psi will be used for the structural calculations.

Finite Element Analysis Results

The following FEA results assume that there is gravel ballast in the base of each section. It is also assumed that there is dirt piled into the chamfers, as shown in the hand calculations.

Item 3:

The following analysis shows a single section of the system with 0.5 psi on the system. There is 71.68 psf on the system (see excel calculations on the following page) with a 200mph wind. This converts to 0.5 psi. This value is placed across the entire surface of the wall.

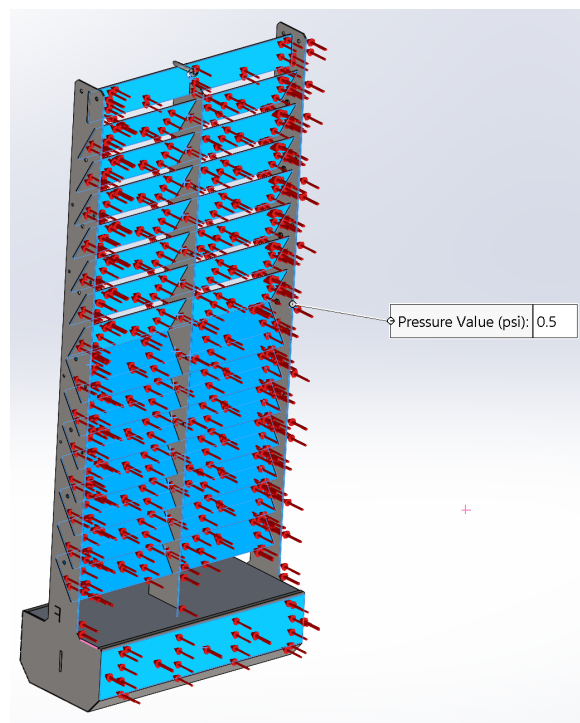

Figure 1: Locations of 0.5 psi

The base and tether points are considered “fixed” to the ground as previous hand calculations proved that the base would not slide out at 200mph wind with the use of tethers and the tethers are assumed to be fixed to an immovable object in the ground.

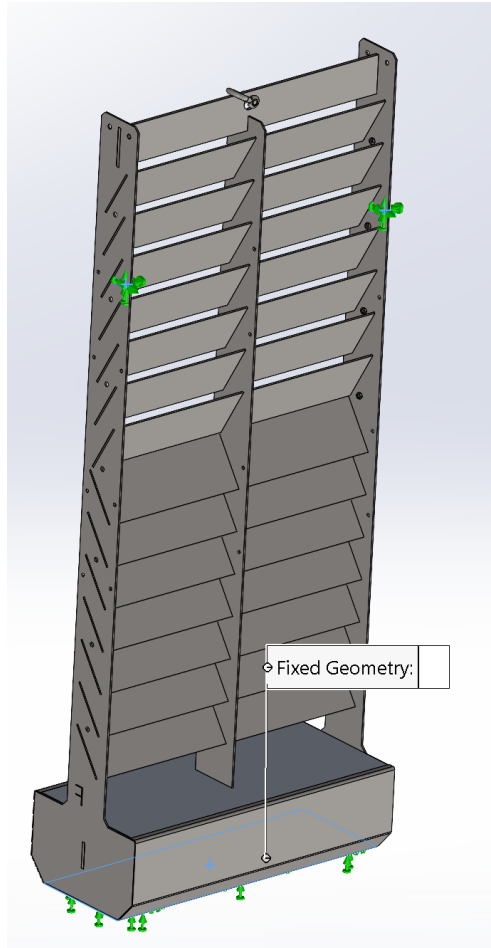

Figure 2: Fixed Geometry

The stress results are shown below. Note that the scale is 0-10,000 psi. The highest stress on the stress plot is 9060 psi. Armor has a yield strength of 220,000 psi. If the scale had been 0-220,000, there would be no visible stress distribution. The scale was lowered to 10,000 psi to illustrate the stress distribution and confirm it is appropriate for the load scenario. This results in a Factor of Safety (FS) of 24 to the yield stress.

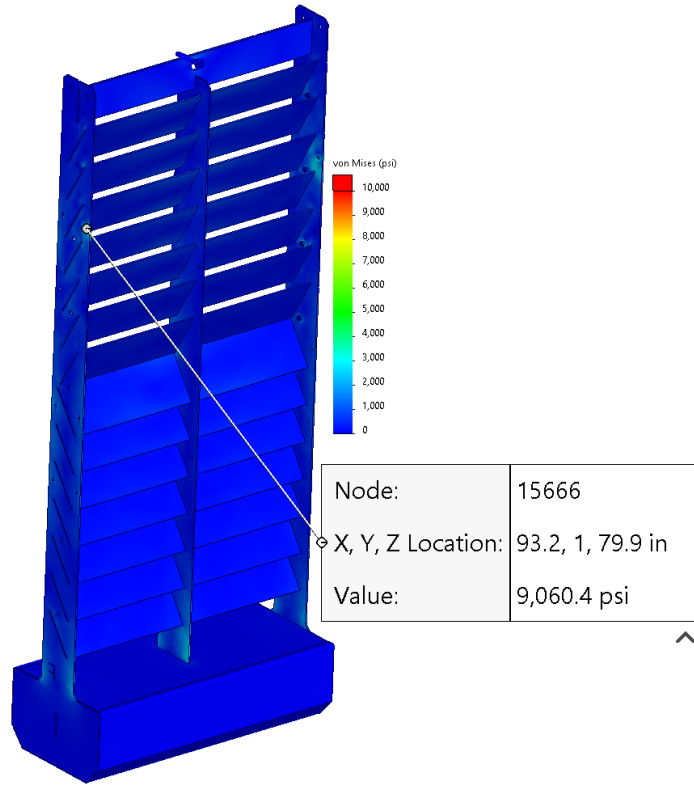

Figure 3: Stress Results, Tethered, Single Section

The deflection results are shown below. Note that the highest deflection calculated is about 0.008". The deflection is shown in the anticipated location based upon the pressure and constraints.

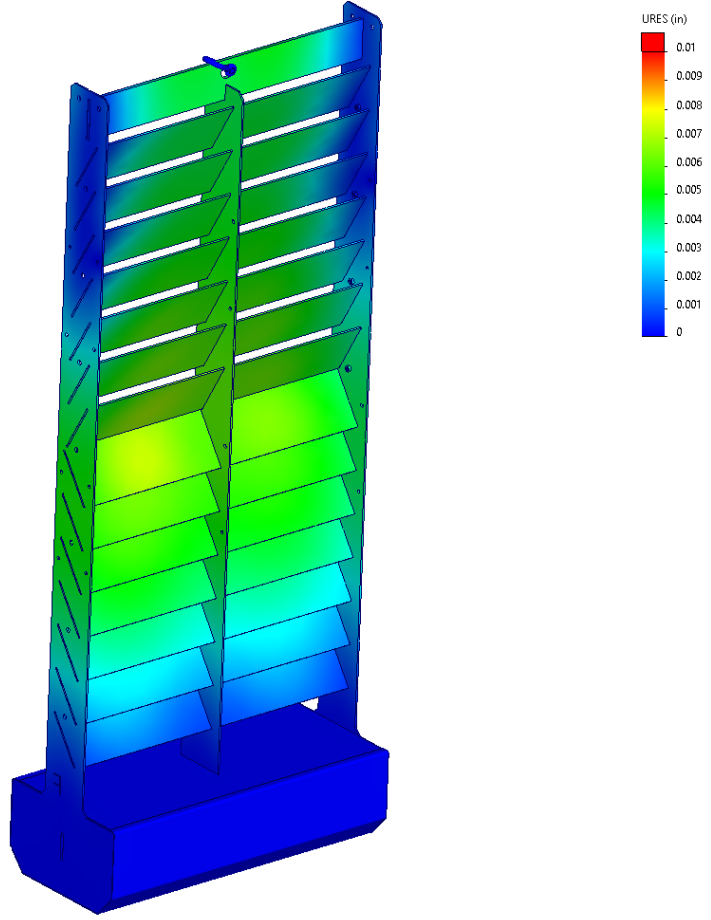

Figure 4: Deflection Results, Tethered, Single Section

Item 4:

The following analysis shows a 5 section system of loaded to 0.5 psi to simulate a 200 mph wind. This is similar to the previous (Item 3) analysis, but put into a larger system.

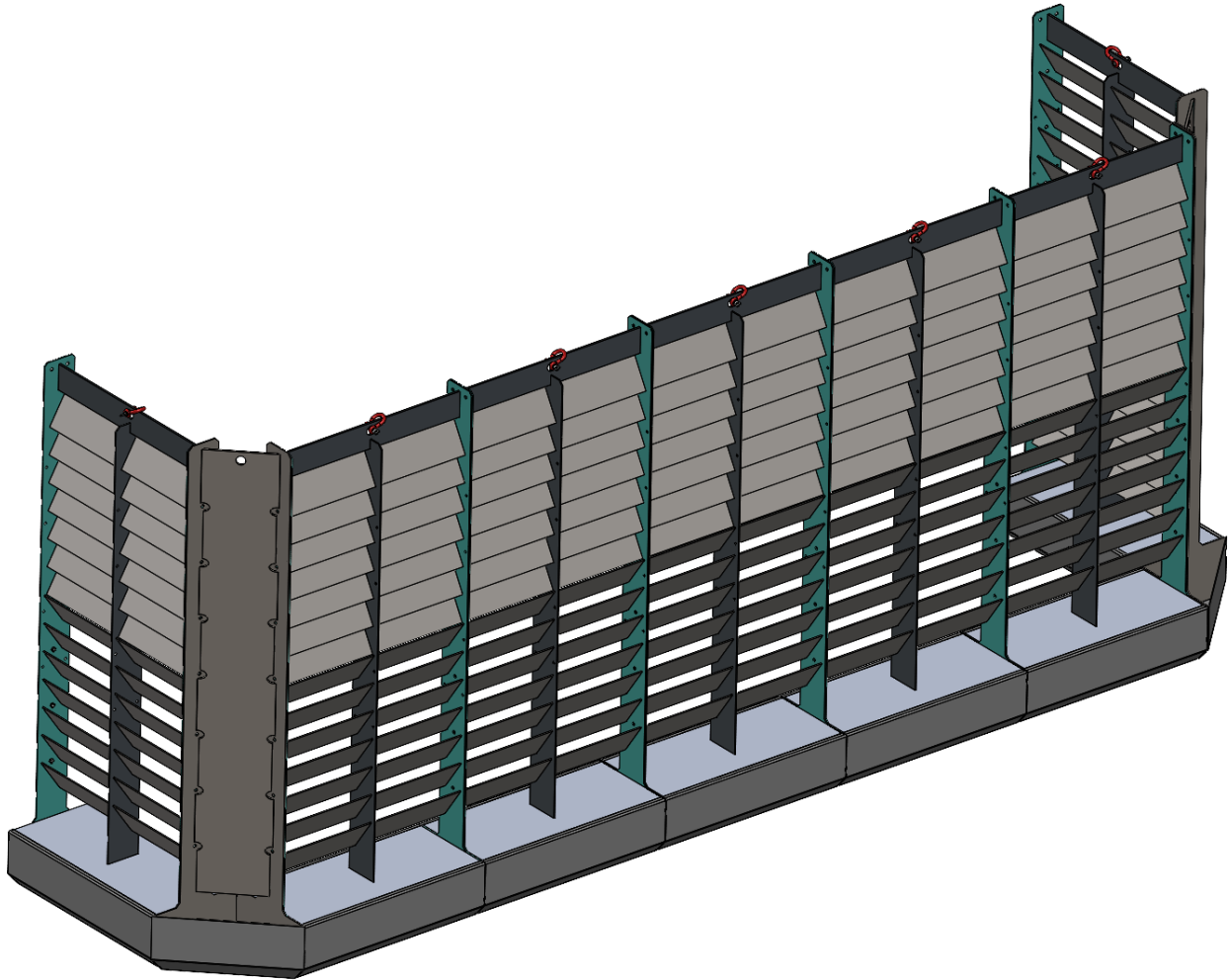

Figure 5: 5 Section System

The pressure application surfaces are shown below (0.5 psi)

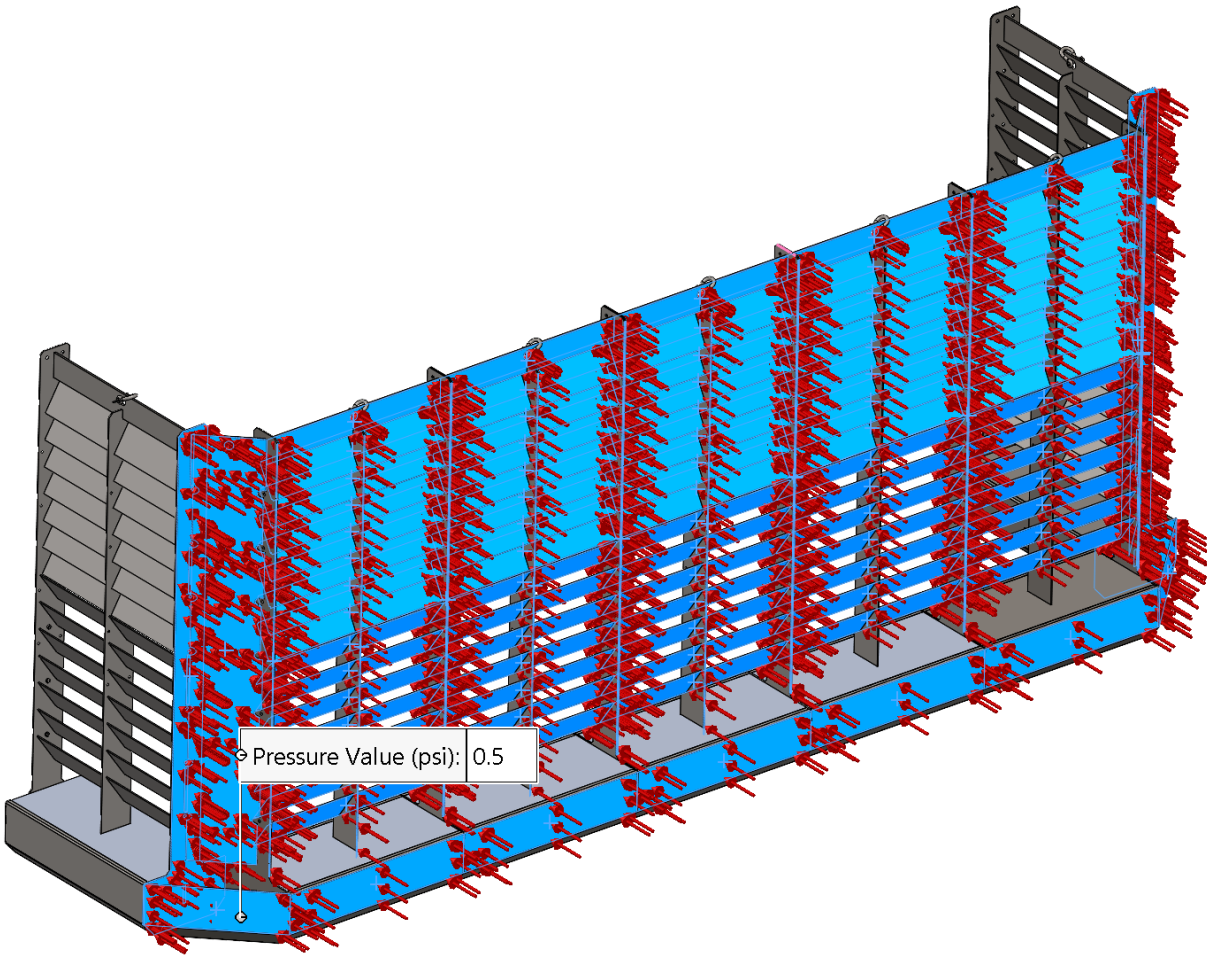

Figure 6: 0.5 psi Distribution

The stress distribution plot is shown in the Figure below. The maximum stress is about 15,600 psi. Note that the scale on the stress plot is 0-18,000 psi. The yield stress of 46100 armor is 220,000 psi. If the scale had been 0-220,000, there would be no visible stress distribution. The scaled was lowered to 18,000 psi to illustrate the stress distribution and confirm it is appropriate for the load scenario. This results in a Factor of Safety of 14 to yield stress. The wall will handle the 200 mph wind speed.

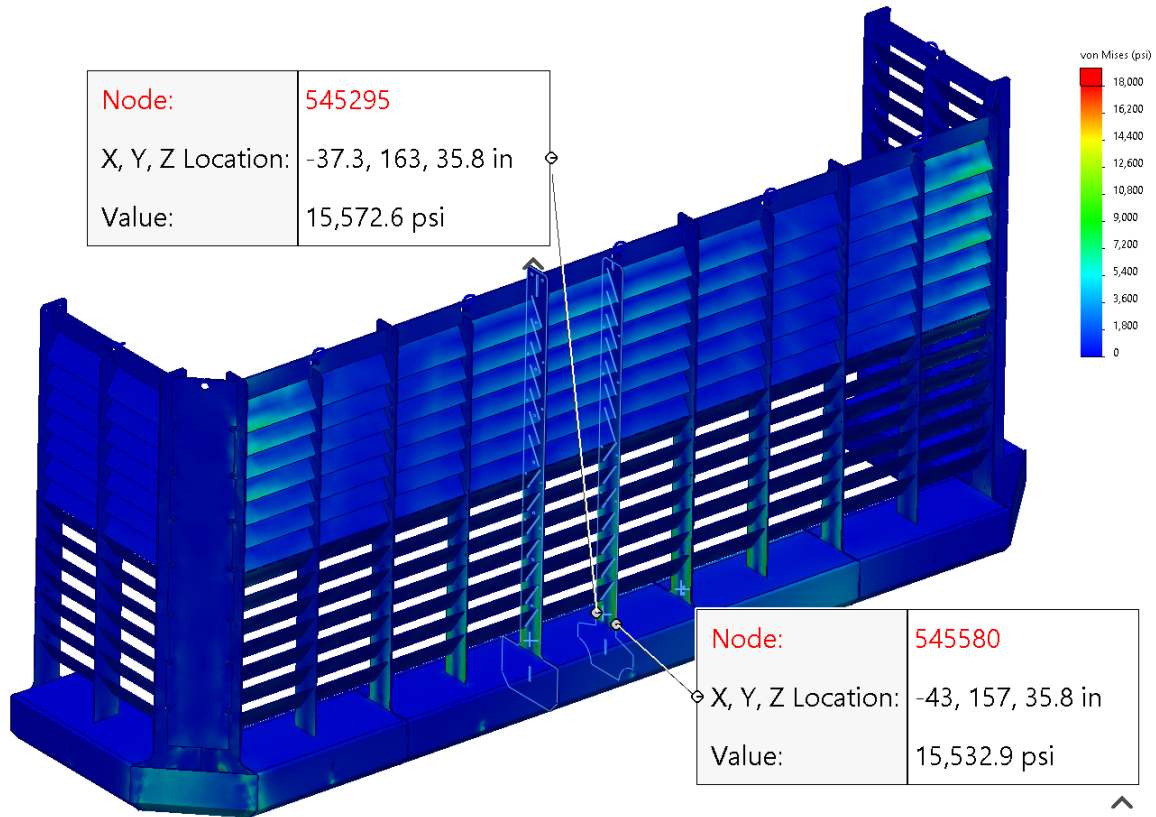

Figure 7: Stress Plot, 5 Section wall, Untethered

The deflection results are shown below. Note that the highest deflection calculated is about 0.35". The deflection is shown in the anticipated location based upon the pressure and constraints.

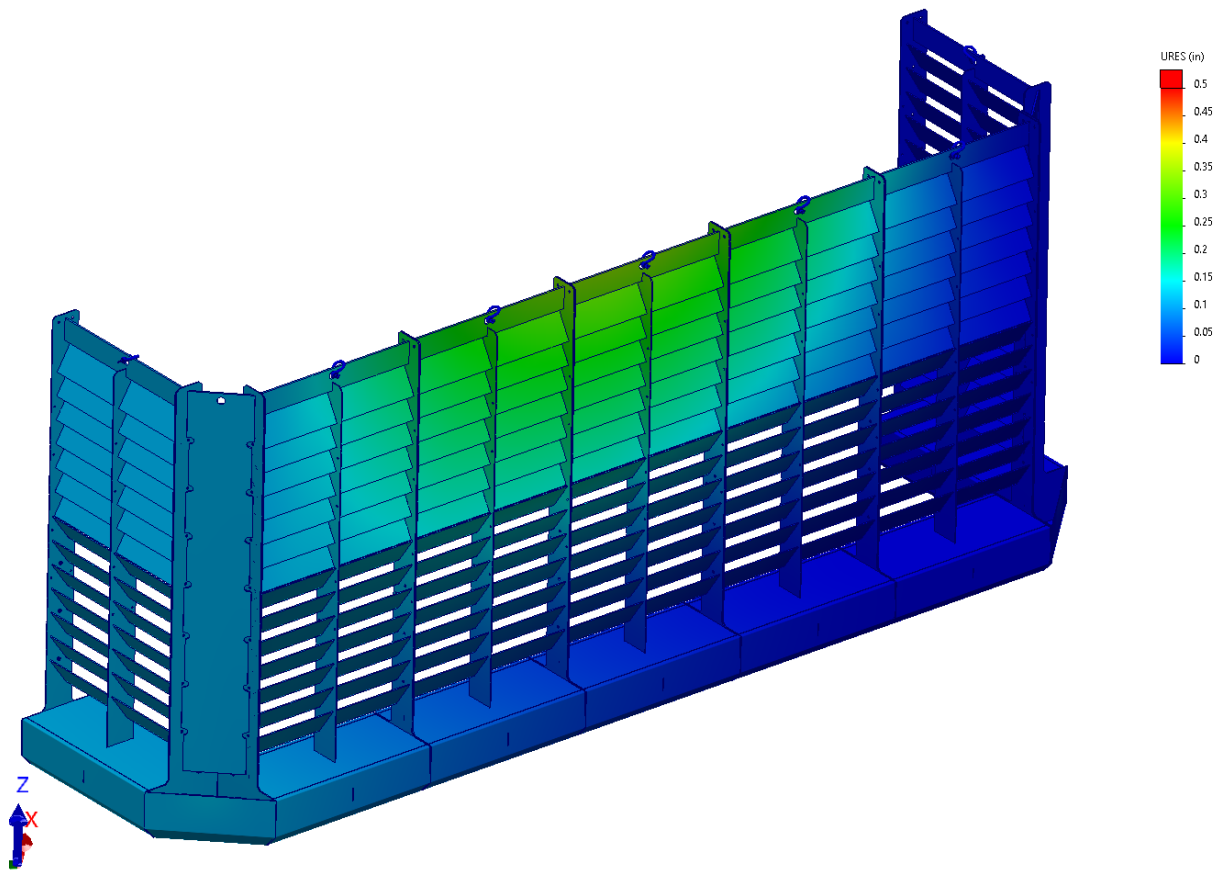

Figure 8: Deflection Plot, 5 Section System, Untethered

Conclusion

The stress, displacement, and factors of safety are within acceptable levels for 200 mph winds. The hand calculations show that a tethered system will provide the strongest setup. The system can be configured in a variety of setups. The setups shown in this report are common, baseline setups, that illustrate the strength of the system. Longer spans and different corner types (ie 45 deg, 60 deg, etc) may require additional analysis or tethers for spans greater than 5 sections.

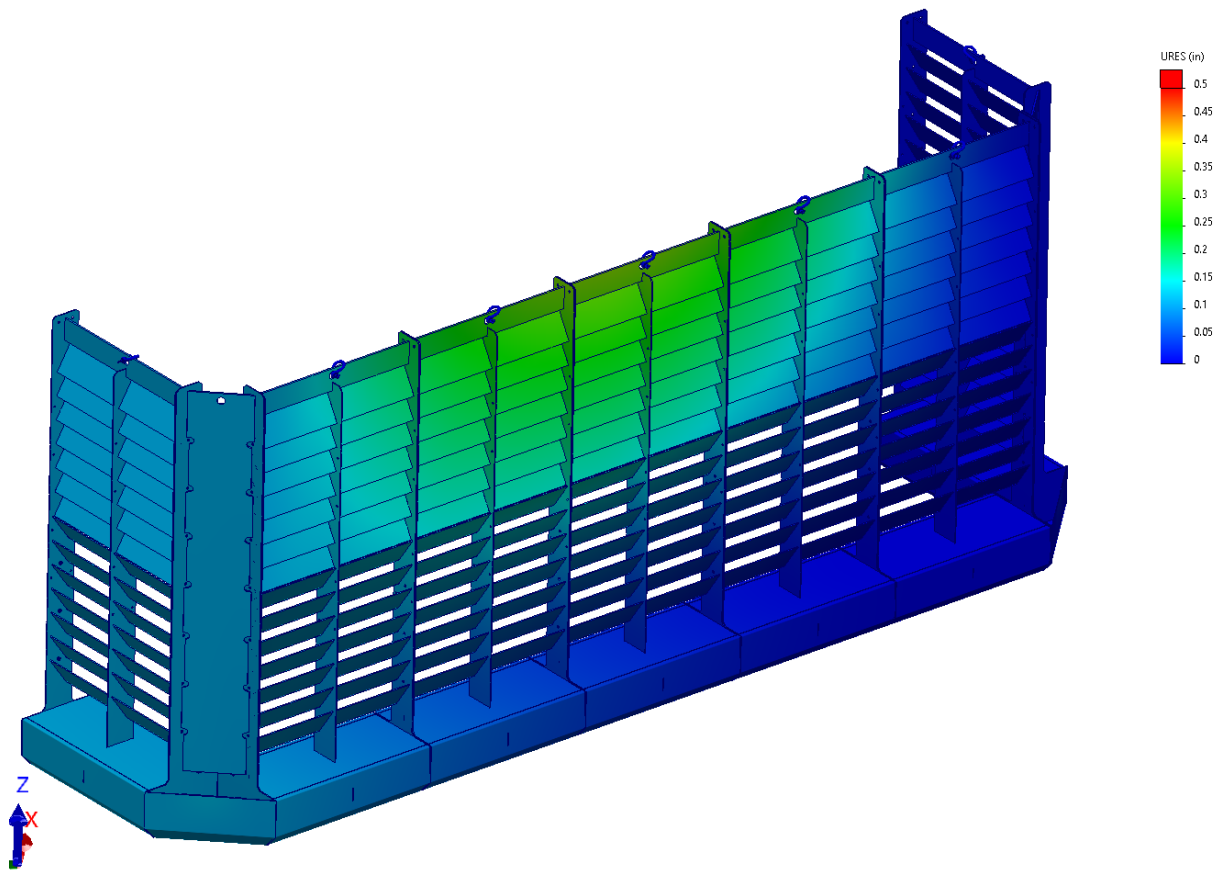

Figure 9: Deflection Plot, 5 Section System, Untethered

Conclusion

The stress, displacement, and factors of safety are within acceptable levels for 200 mph winds. The hand calculations show that a tethered system will provide the strongest setup. The system can be configured in a variety of setups. The setups shown in this report are common, baseline setups, that illustrate the strength of the system. Longer spans and different corner types (ie 45 deg, 60 deg, etc) may require additional analysis or tethers for spans greater than 5 sections.

Appendix 1: CFD Analysis

Parameters:

Fluid: Air

Temperature: 70F

Flow Type: External (Outdoors)

Units: SAE (psi, MPH, ft, lb)

Flow Results

This section of the report was created to communicate general flow trajectories and wind speed through the louvered panels. This section is broken down into different plots to help communicate how the flow passes through and what the wind speed is behind the wall. All references to speed (MPH) are referencing wind speed directly on the wall section.

200 MPH

The wind speed Flow Trajectories shown in Figure 10 (below) illustrate the wind flow through the louvered wall section. This graphic illustration highlights where the wind will flow past the wall at 200 MPH.

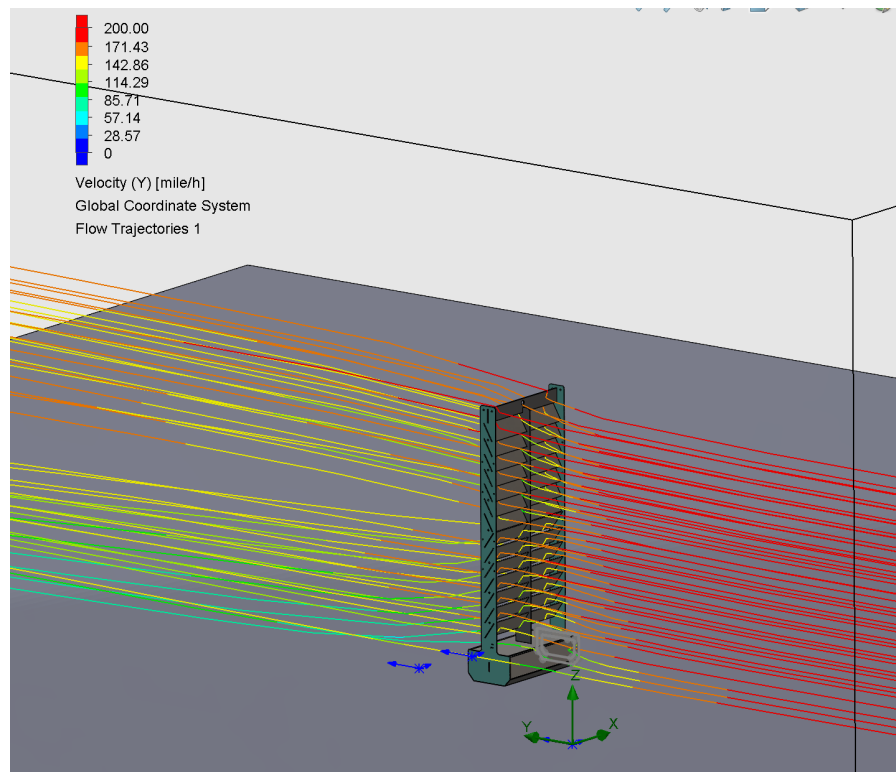

Figure 10: Flow Trajectories at 200 MPH

The following cut plot illustrates the flow trajectories (in MPH) in a different graphic content. This illustrates what the wind speed is on the inside wall when the outside air speed is at 200 MPH, directly into the wall.

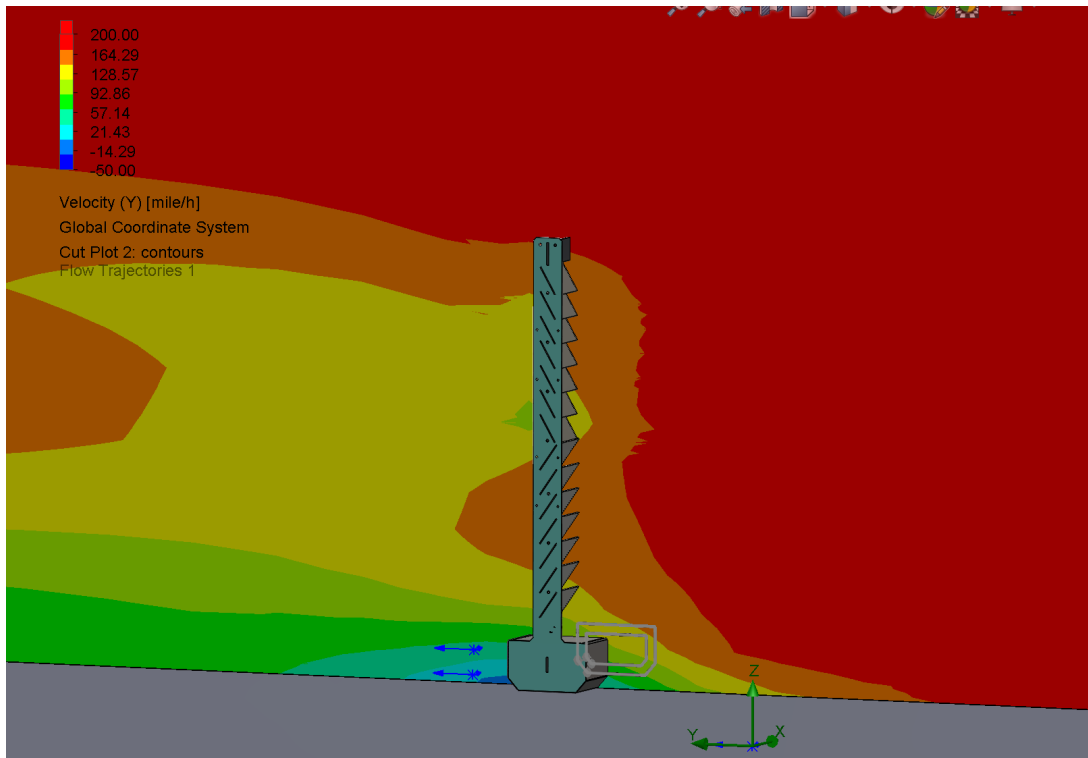

Figure 11: Cut Plot Flow Trajectory 200 MPH

Figure 11 shows a wind speed on the back side of the wall ranging from about 60 mph up to 160 mph from the ground to the top of the wall, respectively. The most predominant wind speed shown is in the 130 MPH range, as illustrated by the color chart.

30MPH

The flow trajectory below (Figure 12) illustrates the flow trajectories at 30 MPH. This flow trajectory shows the red lines as 30 MPH wind and the associated colors as the reduced wind speed, averaging less than 20 MPH on the back side of the wall.

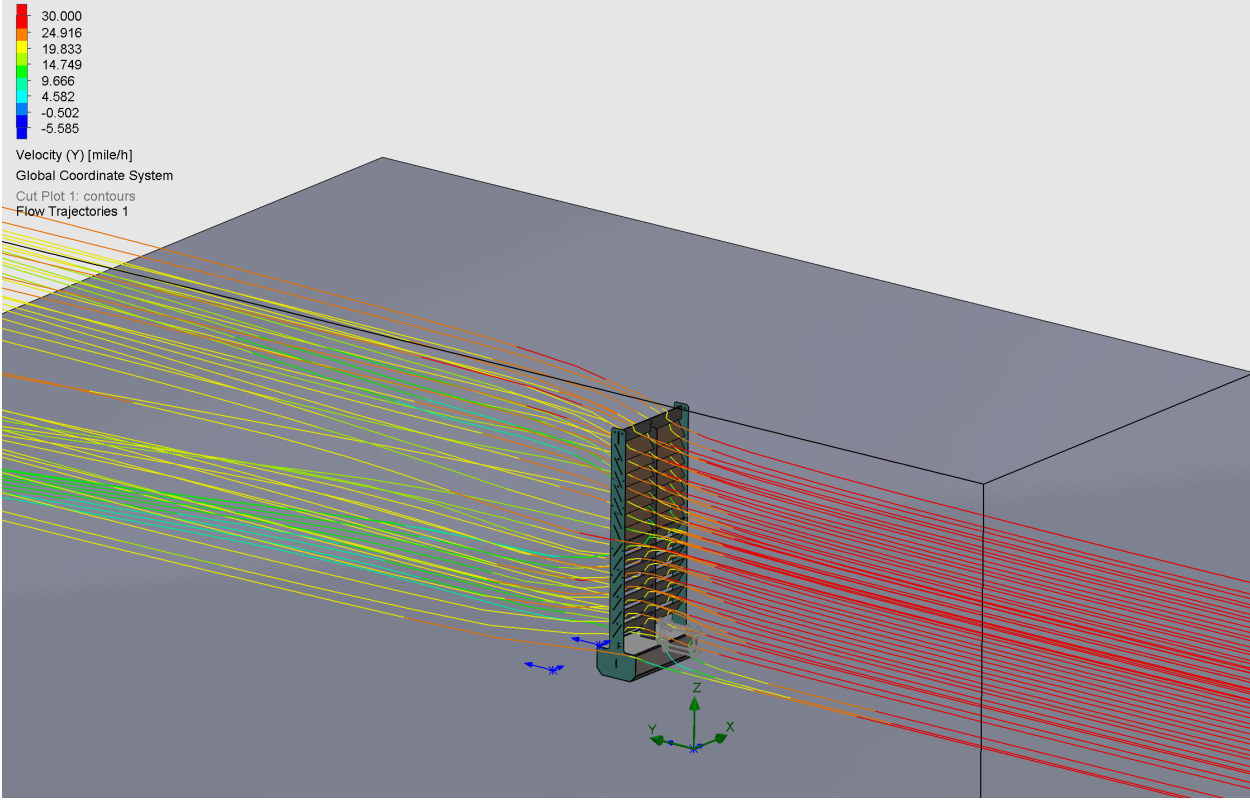

Figure 12: Flow Trajectories at 30 MPH

The cut plot flow trajectory shown below illustrates the flow trajectories better graphically with respect to wind speed. The wind speed is reduced to well under 20 MPH and even shows a slight vacuum at the center of the louvers (minor). The bulk of the wind speed is in the 10-15 MPH range past the wall.

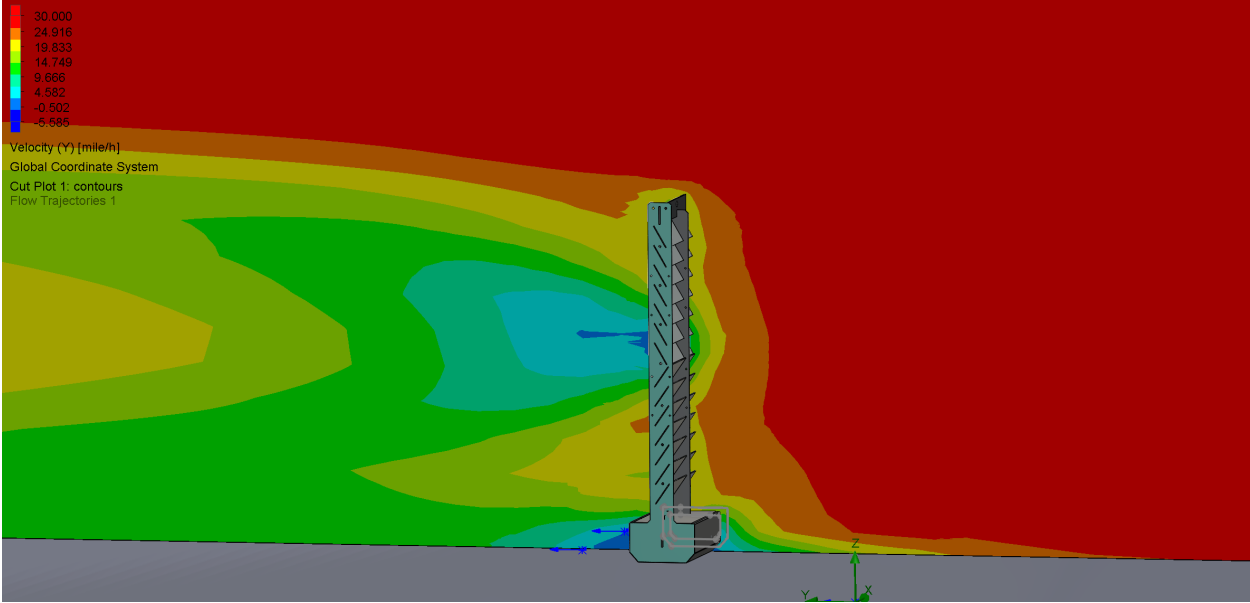

Figure 13: Flow Trajectory Cut Plot at 30 MPH

15 MPH

The following flow trajectory (Figure 14) shows the wind speed starting at 15 MPH and reduced down to about 10MPH when flowing through the louvers. This is an expected performance as the wind speed is reduced as compared to the other analyses.

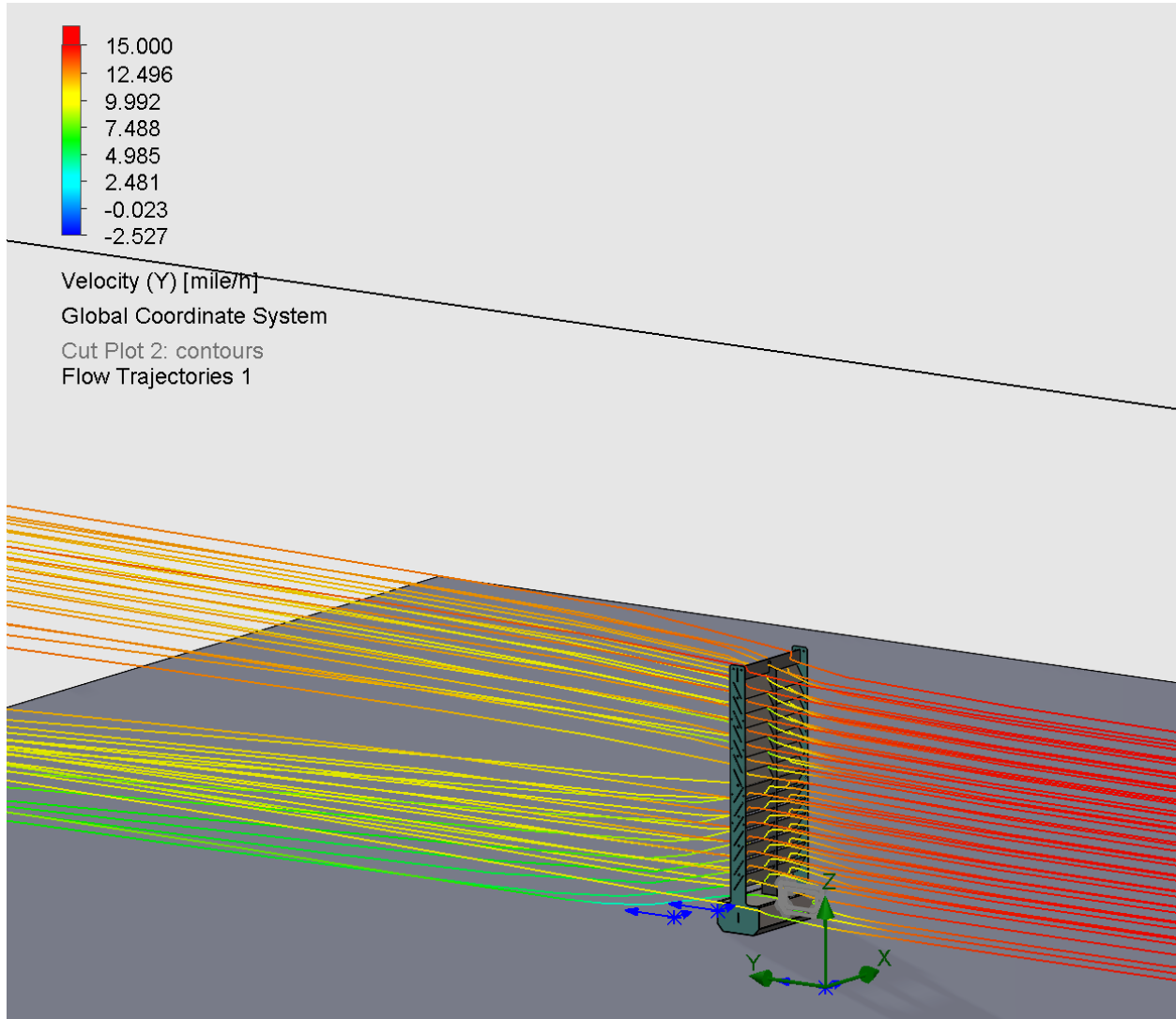

Figure 14: Flow Trajectories at 15 MPH

Figure 15 (below) illustrates a cut plot for the flow trajectory for the wind speed of 15 MPH. This illustrations shows that air does indeed pass through the unit, even at lower wind speeds.

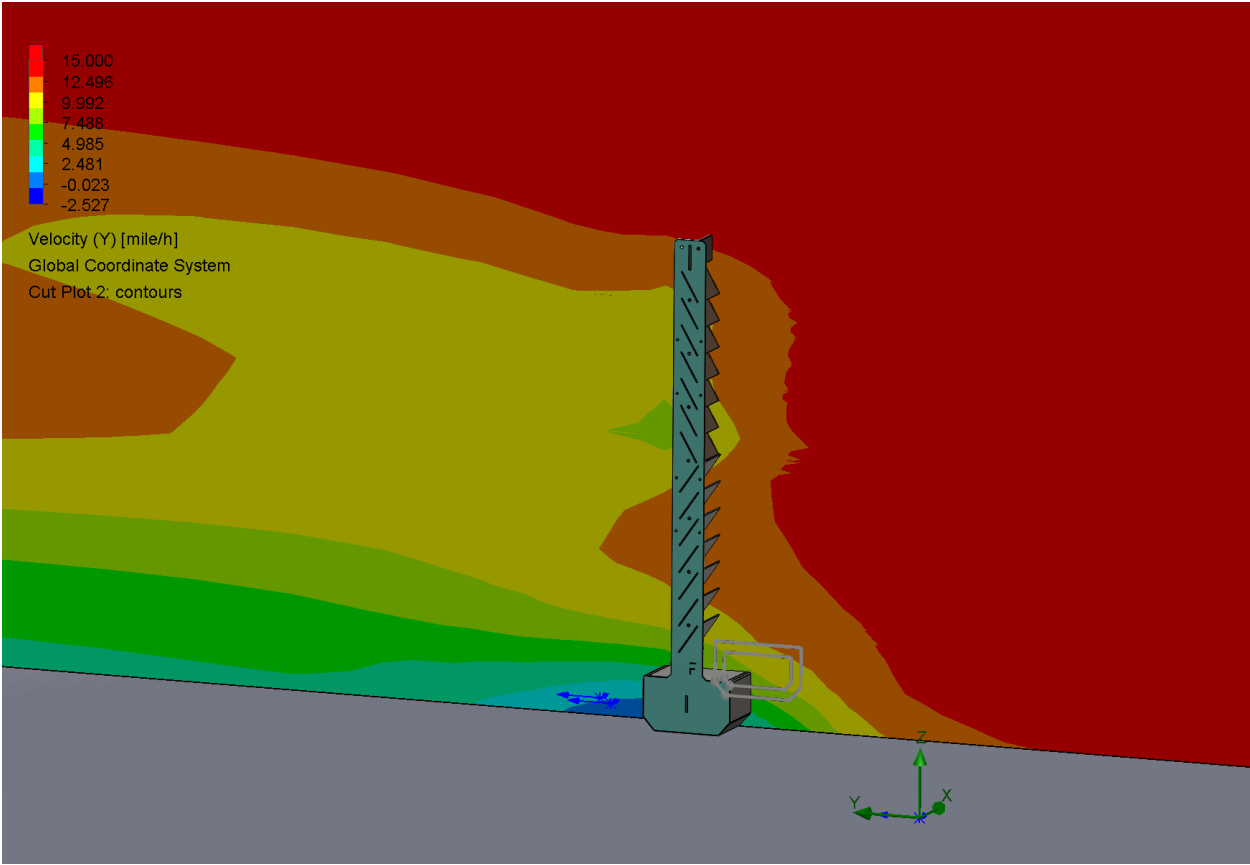

Figure 15: Flow Trajectory Cut Plot at 15 MPH

200MPH – 5 wall section

The illustrations below show flow trajectories for 200 MPH of wind going on (5) sections of the wall. The dark blue coloring indicates an area of vacuum, but with a wind speed of 20 mph towards the wall. There is also a significant reduction in wind speed as compared to one section at the height of the wall. Note that this is a cut plot only and must be compared to a general flow trajectory to understand the entire flow.

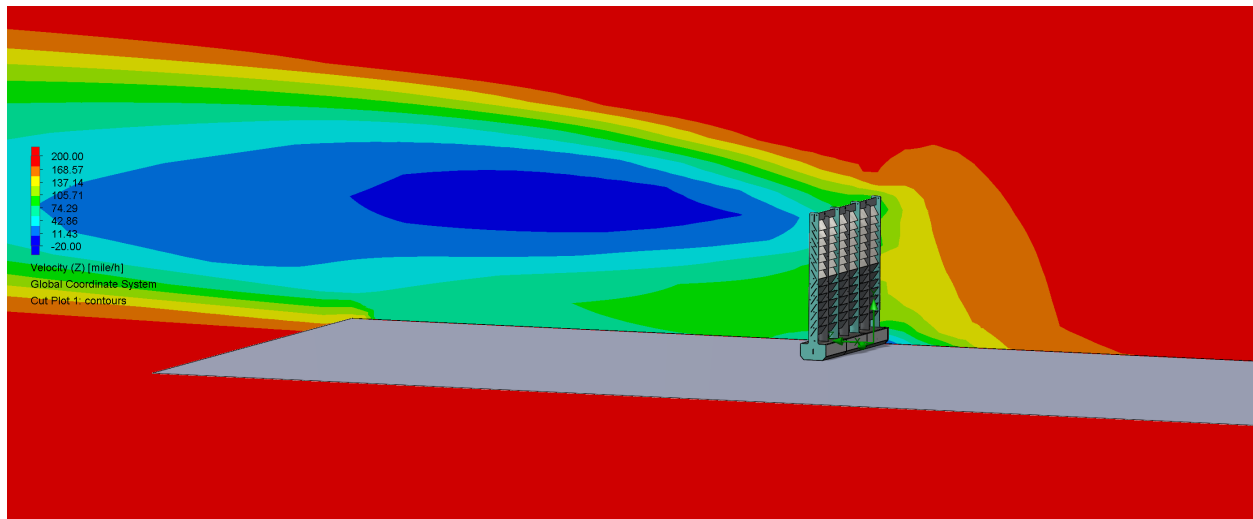

Figure 16: Flow Trajectory Cut Plot 200 MPH, 5 section wall

The flow trajectory shown in Figure 17 indicates the same as the cut plot in Figure 16 with a vacuum deep inside the flow area, but with a smaller magnitude. The dark blue lines indicate the vacuum trajectories, which are significantly fewer than the reduced flow characterized by the lines that show around 75-120 MPH wind speed on average. The vacuum/reverse flow indication in Figure 17 is significantly smaller than what is shown in Figure 16 as Figure 16 only shows a cut plot through one point along the entire wall.

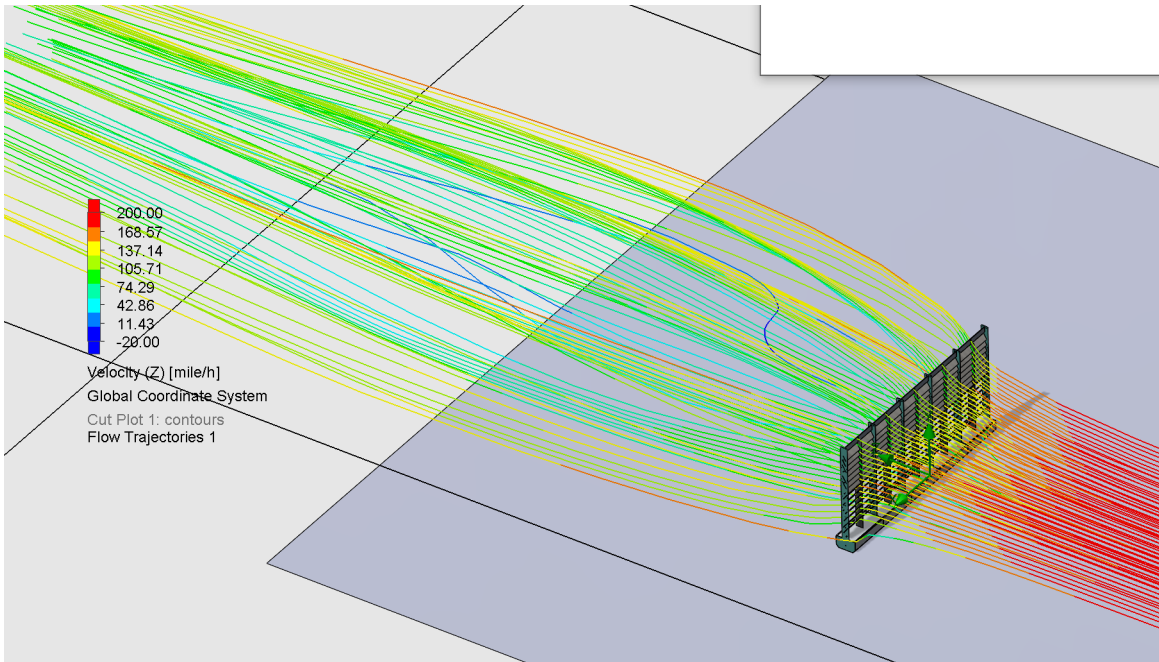

Figure 17: Flow Trajectory 200 MPH, 5 section wall

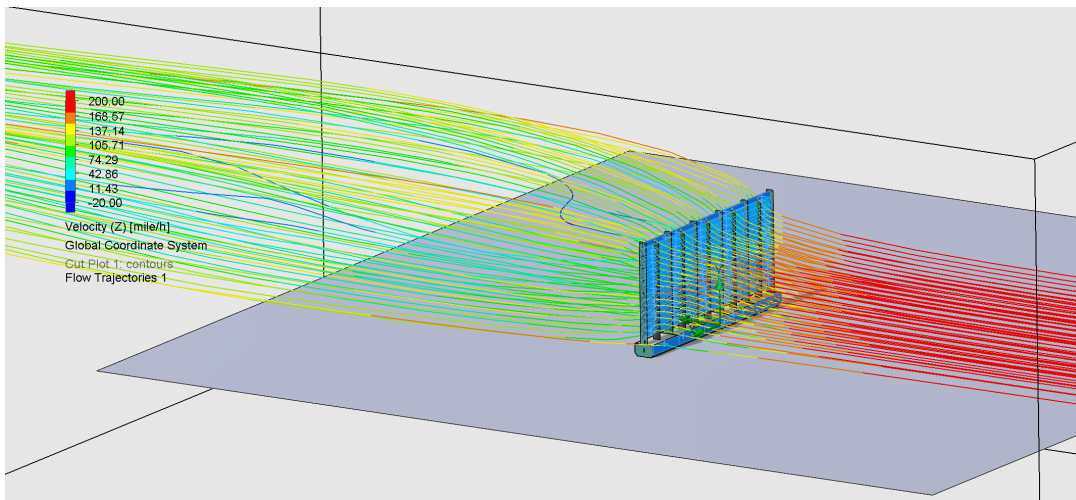

Figure 18: Flow Trajectory 200 MPH 5 section Wall, View 2

Summary:

These flow trajectory plots communicate that significant flow can still pass through the louvers. It is recommended that different configurations are analyzed before installation around any equipment that is sensitive to air flow to confirm appropriate air flow is available to that equipment/area. This appendix set is a generalized approach to how much flow will be available through the louvered walls.